

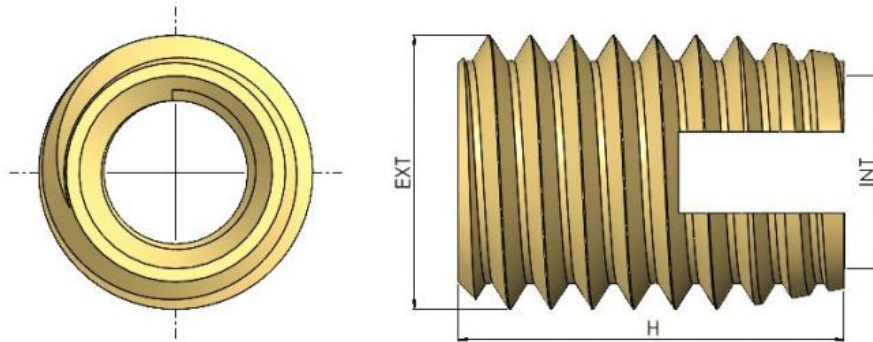

Series: 20105 Type: SC



Screw Fit Inserts

Part No.	INT Thread	EXT Thread	Length H	Hole Dia -200HB	Hole Dia +200HB	Hole Depth P	Weight - Steel
SC025H04__	M2.5	4.0	4.0	4.1	4.2-4.3	5.0	0.030
SC025H06__	M2.5	4.5	6.0	4.1	4.2-4.3	8.0	0.038
SC030H05__	M3	5.0	5.0	4.6	4.7-4.8	7.0	0.042
SC030H06__	M3	5.0	6.0	4.6	4.7-4.8	8.0	0.045
SC035H06__	M3.5	6.0	6.0	5.4-5.5	5.6-5.7	8.0	0.070
SC035H08__	M3.5	6.0	8.0	5.4-5.5	5.6-5.7	10.0	0.078
SC040H07__	M4	6.5	7.0	5.9-6.0	6.1-6.2	9.0	0.090
SC040H08__	M4	6.5	8.0	5.9-6.0	6.1-6.2	10.0	0.092
SC050H08__	M5	8.0	8.0	7.2-7.3	7.5-7.6	10.0	0.145
SC050H10__	M5	8.0	10.0	7.2-7.3	7.5-7.6	13.0	0.159
SC060H10__	M6	9.0	10.0	8.8-9.0	9.2-9.4	12.0	0.175
SC060H12__	M6(a)	9.0	12.0	8.2-8.3	8.5-8.6	15.0	0.235
SC060H14__	M6	10.0	14.0	8.8-9.0	9.2-9.4	17.0	0.358
SC080H13__	M8	12.0	13.0	10.8-11.0	11.2-11.4	16.0	0.485
SC080H15__	M8	12.0	15.0	10.8-11.0	10.2-11.4	18.0	0.509
SC100H16__	M10	14.0	16.0	12.8-13.0	13.2-13.4	19.0	0.715
SC100H18__	M10	14.0	18.0	12.8-13.0	13.2-13.4	22.0	0.778
SC120H22__	M12	16.0	22.0	14.8-15.0	15.2-15.4	26.0	1.116
SC140H24__	M14	18.0	24.0	16.8-17.0	17.2-17.4	28.0	1.470
SC160H22__	M16	20.0	22.0	18.8-19.0	19.2-19.4	27.0	0.500
SC180H24__	M18	22.0	24.0	20.8-21.0	21.2-21.4	29.0	2.045
SC200H27__	M20	26.0	27.0	24.8-25.0	25.2-25.4	32.0	3.912
SC220H30__	M22	26.0	30.0	24.8-25.0	25.2-25.4	36.0	3.200
SC240H30__	M24	30.0	30.0	28.8-29.0	29.2-29.4	36.0	5.442



Continued from previous page...

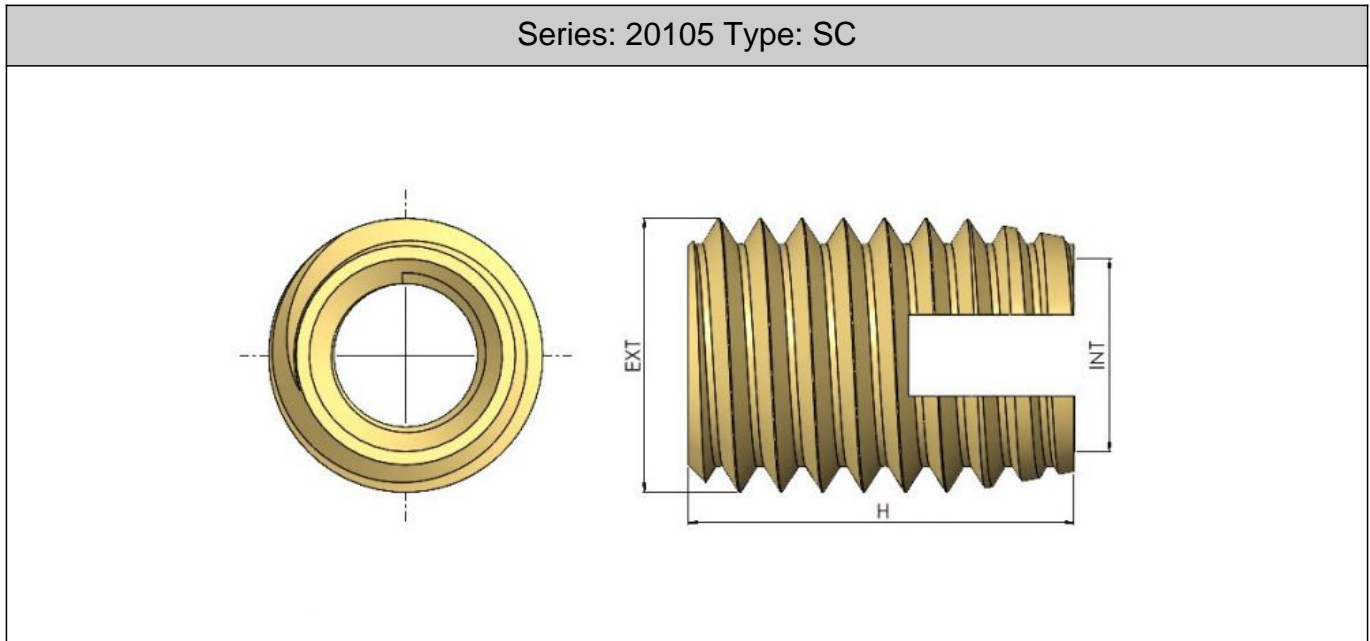

SC270H30__	M27	34.0	30.0	32.8-33.0	33.2-33.4	36.0	7.124
SC300H40__	M30	36.0	40.0	34.8-35.0	35.2-35.4	46.0	9.416

The SC range of self tapping inserts can be used in soft and hard plastics and alloys. The slot at the lead end helps to break away swarf during the tapping process. The extensive range of sizes and materials make them a very versatile insert with many uses. Materials and Finishes:-Brass Self Colour (Code BR)Hardened Steel Zinc Plated for alloys (code CH)Stainless Steel 303 (code SS)To Specify Use: Series No / Part No / Finish Code (eg 20105 SC030H060BR)

All information is given for guidance only and designers should satisfy themselves as to the suitability of the specification by requesting samples