

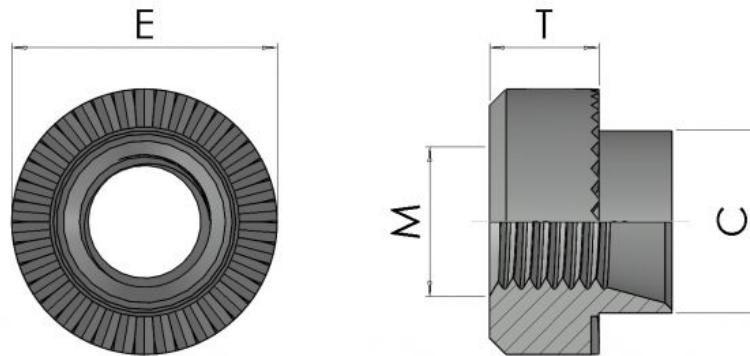

Series: 30101 Type: RSH



Round Rivet Bush

Part No.	Thread	Hole Size +.05-0	E +/-0.15	T +/-0.13	C +0 / -.13
M25??RSH	M2.5	5.54	7.92	3.17	5.54
M3??RSH	M3	5.54	7.92	3.17	5.54
M35??RSH	M3.5	6.73	9.52	3.17	6.73
M4??RSH	M4	6.73	9.52	3.17	6.73
M5??RSH	M5	7.92	11.10	3.81	7.92
M6??RSH	M6	9.52	12.7	5.08	9.52
M8??RSH	M8	12.70	15.9	6.35	12.70
M10??RSH	M10	15.87	19.05	7.62	15.87
M12??RSH	M12	19.05	25.40	10.16	19.05

Legend	
*	Usually Available from Stock
**	Non-preferred (Possible Lead Times)
***	Special Order Only

SWG/MM	M2.5	M3	M3.5	M4	M5	M6	M8	M10	M12
8G/4.0	***	***	***	***	***	***	***	**	**
10G/3.0	***	**	**	**	**	*	*	*	*
12G/2.5	**	**	**	**	*	*	*	*	*
14G/2.0	**	*	**	*	*	*	*	*	*
16G/1.6	**	*	**	*	*	*	*	**	**
18G/1.2	**	*	**	*	*	*	*	**	**



Continued from previous page...

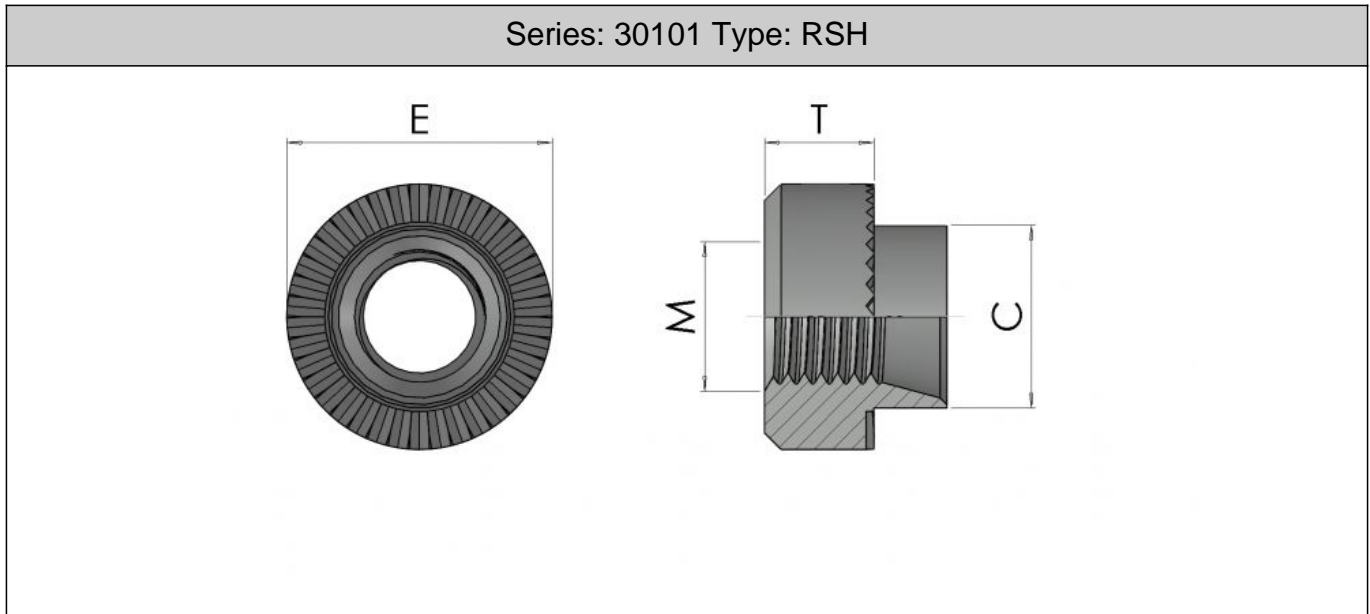

20G/1.0	**	*	**	*	*	**	**	***	***
---------	----	---	----	---	---	----	----	-----	-----

Round Rivet Bushes provide a strong female thread in sheet metal. The spigot is placed through a pre-punched hole and riveted on the reverse side, the serrations under the head provide excellent torque resistance. Various spigot lengths are available for different sheet thicknesses.

Materials & Finishes:-Steel Self Colour (Code 2)Steel Trivalent Zinc (Code 26)303 Stainless Steel (Code SS)

To Specify Use: Series No/Part No/Gauge/Finish Code (eg 30101 M320RSH26)

Preferred Sizes:

All information is given for guidance only and designers should satisfy themselves as to the suitability of the specification by requesting samples