

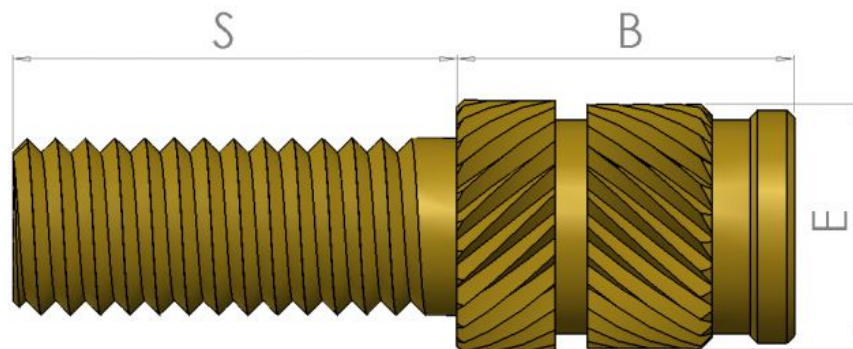

Series: 20106 Type: ISS



Heatstake / Ultrasonic Stud

Part No.	Thread A	Ext. Diam. E	Length B	Stud length S	Hole dia. L+0.1	Min Wall W
ISS020L_ _	M2.0	3.60	4.00	6-16	3.2	2.0
ISS025L_ _	M2.5	4.60	5.80	6-16	4.0	2.3
ISS030L_ _	M3.0	4.60	5.80	6-16	4.0	2.3
ISS035L_ _	M3.5	5.40	7.20	6-25	4.8	2.5
ISS040L_ _	M4.0	6.30	8.20	6-25	5.6	2.5
ISS050L_ _	M5.0	7.00	9.50	6-25	6.4	2.7
ISS060L_ _	M6.0	8.60	12.70	6-25	8.0	3.0
ISS080L_ _	M8.0	10.20	12.70	10-25	9.6	3.5

The ISS Insonic Range of Inserts have the same features as the IS range but with a male thread. They can be installed with ultrasonic or heat insertion machines in all thermo plastics. The unique opposing helix knurl provides exceptional resistance to torque loads and facilitates the flow of plastic into the two recessed grooves providing greater pullout loads than alternative designs. Materials and Finishes: Brass Self Colour (nickel plated on request) 303 Stainless Steel (code S) special order only check with sales dept. To Specify Use: Series No / Part No / Length (eg 20106 ISS050L15 M5x15 long stud)

All information is given for guidance only and designers should satisfy themselves as to the suitability of the specification by requesting samples